



1100 Series

1106C-E66TAG4

Diesel Engine - ElectropaK

175.5 kWm @ 1500 rev/min
196.3 kWm @ 1800 rev/min

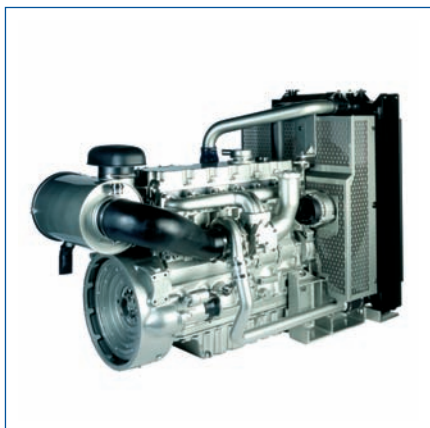

Power to Meet your Needs

Hitting the key power nodes required by the market, the 1106C-E66TAG4 ElectropaK has been developed to provide a clean and cost effective power solution.

State of the Art Design

The 1106C-E66TAG4 incorporates the latest common-rail fuel system technologies with a closely optimised air-management system which is overseen by the latest generation of electronic engine control. This allows the 1106C ElectropaK range to deliver high power density, low exhaust emissions with the minimum of heat rejection and excellent fuel economy.

Worldwide Power Solution

The 1106C has been designed to be worldwide fuel tolerant, including kerosene, jet aviation fuel and 5% biofuel (RME). Options are available to meet local market needs.

Product Support

- Perkins actively pursues product support excellence by ensuring our distribution network invest in their territory - strengthening relationships and providing more value to you, our customer
- Through an experienced global network of distributors and dealers, fully trained engine experts deliver total service support around the clock, 365 days a year. They have a comprehensive suite of web based tools at their fingertips covering technical information, parts identification and ordering systems, all dedicated to maximising the productivity of your engine
- Throughout the entire life of a Perkins engine, we provide access to genuine OE specification parts and service. We give 100% reassurance that you receive the very best in terms of quality for lowest possible cost .. wherever your Perkins powered machine is operating in the world

Long-term Power Solution

The 1106C-E66TAG ElectropaK range has been designed to fully comply with EU Stage II emissions regulations, providing an emissions compliant power solution for the future.

The 1106C-E66TAG ElectropaKs are the latest addition to Perkins 1100 Series Electric Power line-up. Offering improved power density from a compact package, these ElectropaK's build on Perkins reputation within the Power Generation Industry.

These ultra clean engines are assembled on a new high technology production line. Frequent computerised checks during the production process ensure high build quality is maintained throughout.

Hitting the key power nodes required by the market, the 1106C-E66TAG product line-up consists of three models offering a power solution for both Prime and Standby applications, in 50 Hz and 60 Hz territories.

Certified against the requirements of EU2007 legislation for non-road mobile machinery, powered by constant speed engines (EU97/68/EC Stage II).

Engine speed (rev/min)	Type of Operation	Typical generator output (net)		Engine power			
				Gross		Net	
		kVA	kWe	kWm	bhp	kWm	bhp
1500	Prime	180.0	144.0	163.3	218.9	158.4	212.4
	Standby (maximum)	200.0	160.0	180.4	242.0	175.5	235.3
1800	Prime	200.0	160.0	185.3	248.4	177.3	237.7
	Standby (maximum)	219.0	175.0	204.3	274.0	196.3	263.2

The above ratings represent the engine performance capabilities to conditions specified in ISO 8528/5 Derating may be required for conditions outside the test conditions; consult Perkins Engines Company Limited Generator powers are typical and are based on typical alternator efficiencies and a power factor Fuel specification: Consult Perkins Engines Company Limited (various fuel specifications are available) Lubricating oil: multi-grade oil conforming to API-CH4/C14 must be used

Rating Definitions

Prime Power: Power available at variable load in lieu of a main power network. Overload of 10% is permitted for 1 hour in every 12 hours' operation Standby (maximum): Power available at variable load in the event of a main power network failure. No overload is permitted

1100 Series

1106C-E66TAG4

Standard ElectropaK Specification

Air inlet

- Mounted air filter and turbocharger

Cooling system

- 27" belt-driven pusher fan and guards
- Radiator (incorporating air-to-air charge cooler + fuel cooler)
- Water pump

Electric system

- 12 volt starter motor
- 12 volt, 100 amp alternator with DC output

Flywheel and housing

- High inertia flywheel
- SAE2 flywheel housing

Fuel system

- Electronic governing (confirms to Class G3 ISO 8528-5)
- Fuel filter

Literature

- User's Handbook

Lubrication system

- Flat-bottomed isolated aluminium sump
- Oil filter

Start aids

- Glow plugs

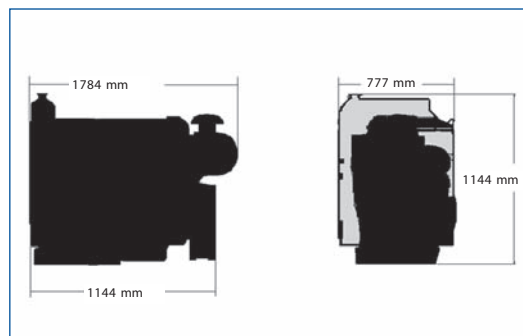

Engine Speed	Fuel Consumption			
	1500 rev/min		1800 rev/min	
	g/kWh	l/hr	g/kWh	l/hr
Standby	204.9	44.0	207.5	50.5
Prime power	206.9	40.2	211.1	41.3
110% of prime power	205.1	43.8	208.0	50.4
75% of prime power	212.7	31.0	222.7	36.8
50% of prime power	211.6	20.5	231.6	25.5

General Data

Number of cylinders	6 in-line
Bore and stroke	105 mm x 127 mm
Displacement	6.6 litres
Aspiration	Turbocharged air-to-air charge cooled
Cycle	4 stroke
Combustion system	Direct injection
Compression ratio	16.2:1
Rotation	Anti-clockwise viewed on flywheel
Cooling system	Water
Dimensions	Length 1784 mm* Width 777 mm Height 1144 mm
Dry weight	714 kg
Wet weight	757 kg

* Length includes air cleaner
Final weight and dimensions will depend on completed specification

Industrial Power Generation Ltd,
Carcroft Enterprise Park,
Station Road, Carcroft,
Doncaster, DN6 8DD, UK

sales@generator.co.uk

Tel: 00 44 (0)845 166 5537

Fax: 00 44 (0)1302 721202



Industrial Power Generation Ltd