

1300 Series

1306C-E87TAG3

Diesel engine - ElectropaK

199 kWm 1500 rev/min

220 kWm 1800 rev/min

The Perkins 1300 Series family of ElectropaK engines has become renowned throughout the power generation industry for the engines' superior performance and reliability.

The 1306C-E87TAG3 engine is a turbocharged and air-to-air charge cooled unit, featuring hydraulically-actuated electronically controlled unit injectors (HEUI) with 'full authority' electronic engine management providing reliable, quiet, economic operation supported by the quick starting, fast response and close control demanded by the electrical power generation market.

High Performance Productive Power

- Hydraulically actuated Electronically controlled Unit Injectors – high-pressure fuel injection gives consistent, reliable high performance.
- Constant electronic engine management and monitoring enable precise fuel metering and injection timing to ensure reliable low temperature starting, superb economy with performance and very close governing.

Quiet, Clean Power

- A rigid structure minimises noise transmission and helically cut gears provide quiet power transfer to auxiliaries.
- Forced induction and electronic fuel injection control combine to reduce combustion noise while electronically optimised fuel/air mixing ensures complete combustion resulting in virtually smoke free operation with emissions capability matching current and future emissions legislation.

Durable Power

- A fully balanced induction-hardened steel crankshaft gives smooth performance with minimised bearing loads.
- Oil cooled pistons with keystone top and second rings give longer life while positive rotational valves and roller cam followers reduce wear on valve seats, tappets and cam lobes.

Reliable Power

- Cylinder head coolant is directed to valve bridges and injectors and lubricating oil is cooled in a high efficiency oil cooler, both features enhancing engine reliability.
- Electronic safety shutdown option protects the engine while event and fault warning codes protect operations.

Easy Maintenance

- Electronic diagnostics help to keep the engine at its productive best while enabling the operator to plan maintenance. Oil and filter changes at 450 hours reduce down time.
- All engines are supported by the Perkins worldwide network of 4,000 distributors and dealers.

Certified against the requirements of EU2007 (EU97/68/EC Stage II) legislation for non-road mobile machinery, powered by constant speed engines.

Engine Speed (rev/min)	Type of Operation	Typical Generator Output (net)		Engine Power			
		kVA	kWe	Gross		Net	
				kWm	bhp	kWm	bhp
1500	Baseload Power	189	151	169	227	164	220
Rating Code	Prime Power	208	166	186	250	180	243
M428	Standby (maximum)	229	183	205	275	199	267
1800	Baseload Power	209	167	188	252	182	244
Rating Code	Prime Power	231	185	207	277	201	269
M430	Standby (maximum)	253	202	227	305	220	296

1500/1800 rev/min switchable ratings are offered for stand-alone non-load sharing gen set applications. Rating code M165 applies.
The above ratings represent the engine performance capabilities to conditions specified in ISO 8528/1, ISO 3046/1:1986, BS5514/1, DIN 6271.

Derating may be required for conditions outside these; consult Perkins Engines Company Limited
Generator powers are typical and are based on an alternator efficiency of 92% and a power factor of 0.8. Performance tolerance is $\pm 5\%$
Fuel specification: BS 2869: Part 2 1998 Class A2 or ASTM D975 D2
Lubricating oil: 15W40 to ACEA E3 or API CG4

Rating Definitions

Baseload power: Power available for continuous full load operation. Overload of 10% permitted for 1 hour in every 12 hours' operation

Prime power: Power available at variable load with a load factor not exceeding 80% of the prime power rating. Overload of 10% is permitted for 1 hour in every 12 hours' operation

Standby power (maximum): Power available at variable load in the event of a main power network failure up to a maximum of 500 hours per year of which up to 300 hours may be continuous. No overload is permitted.

1300 Series

1306C-E87TAG3

Standard ElectropaK Specification

Air inlet

- Mounted air filter and turbocharger

Fuel system

- Hydraulically actuated electronically controlled unit fuel injectors with full authority electronic control
- Electronic governing to ISO 3046-4 with stand-alone isochronous or load-sharing capabilities
- Spin-on fuel filter with pre-filter and hand primer pump

Lubrication system

- Wet rear well steel sump with filler and dipstick
- Full flow spin-on filters
- Tube-type oil cooler thermostatically controlled

Cooling system

- Thermostatically controlled with belt driven circulating pump and 28 inch belt-driven fan
- Radiator mounted with all guards and pipes
- Air/air charge cooler incorporated in radiator
- Coolant filter/conditioner

Electrical equipment

- 24V starter motor and 24V 45 amp alternator with DC output
- Electronic Control Module mounted on engine with wiring looms and sensors
- 3 level engine protection system

Flywheel and housing

- High inertia flywheel to SAE 3 J620 Size 11 1/2
- Cast iron SAE 2 flywheel housing

Mountings

- Front engine mounting bracket

Optional equipment

- 12V starter and alternator
- 12V ECM
- Sensor positions for:
 - oil pressure
 - oil temperature
 - coolant temperature
- SAE 1 flywheel housing and flywheel
- Turbocharger exhaust outlet
- User's handbook and parts manual
- Workshop manual

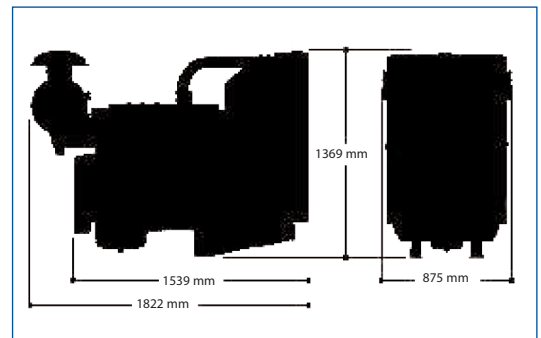

Engine Speed	Fuel Consumption			
	1500 rev/min		1800 rev/min	
	g/kWh	l/hr	g/kWh	l/hr
Standby	204	49.1	213	56.9
Prime power rating	207	45.2	211	51.5
75% of prime power	213	35.0	211	38.5
50% of prime power	219	24.0	218	26.5

General Data

Number of cylinders	6
Cylinder arrangement	Vertical in-line
Cycle	4 stroke
Induction system	Turbocharged, air-to-air chargecooled
Combustion system	Direct injection
Cooling system	Water-cooled
Bore and sstroke	116.6 mm x 135.9 mm
Displacement	8.7 litres
Compression ratio	16.9:1
Direction of rotation	Anti-clockwise, viewed on flywheel
Total lubrication	26.4 litres
System capacity	
Total coolant capacity	37.2 litres
Dry weight (engine)	895 kg
Length	1822 mm
Width	875 mm
Height	1369 mm

Industrial Power Generation Ltd,
Carcroft Enterprise Park,
Station Road, Carcroft,
Doncaster, DN6 8DD, UK

sales@generator.co.uk

Tel: 00 44 (0)845 166 5537

Fax: 00 44 (0)1302 721202



Industrial Power Generation Ltd