

Technical Data

4000 Series

Diesel Engine - Electropak

4006-23TAG1A
4006-23TAG2A
4006-23TAG3A

Basic technical data

Number of cylinders 6
Cylinder arrangement Vertical, In line
Cycle 4 stroke, compression ignition
Induction system Turbocharged
Compression ratio 13.6:1 nominal
Bore 160 mm
Stroke 190 mm
Cubic capacity 22,921 litres
Direction of rotation Anti-clockwise viewed on flywheel
Firing order 1, 5, 3, 6, 2, 4
Cylinders 1 furthest from flywheel
Total weight of Electrounit (engine only)
-dry 2524 kg
-wet 2663 kg

Overall dimensions

Height 1964 mm
Length 3027 mm
Width 1706 mm

Moment of inertia

Engine 4.59 kgm²
Flywheel 6.02 kgm²
Cyclic irregularity for engine/flywheel (prime power):

1500 rev/min	TAG1A: 1:72	TAG2A: 1:67	TAG3A: 1:62
1800 rev/min	TAG1A: 1:113	TAG2A: 1:105	TAG3A: 1:97

Ratings

Steady state speed stability at constant load ± 0.25%
Electrical ratings are based on average alternator efficiency and are for guidance only (0.8 power factor being used).

Operating point

Engine speed 1500/1800 rev/min
Static injection timing See engine number plate
Cooling water exit temp. 98 °C Max.

Fuel data

To conform to BS2869 class A2.

Performance

Estimated sound pressure level 1500/1800 rev/min . 106/111 dBA
Note: All data based on operation to ISO 3046/1, BS 5514 and DIN 6271 standard reference conditions.

Test Conditions

Air temperature 25 °C
Barometric pressure 100 kPa
Relative humidity 30%
Air inlet Restriction at maximum power (nominal) 2,5 kPa
Exhaust back pressure (nominal) 3,0 kPa
Fuel temperature (inlet pump) 58 °C maximum
For test conditions relevant to data on load acceptance, refer to the Applications Department.

General installation 4006-23TAG1A

Designation	Units	50 Hz 1500 rev/min			60 Hz 1800 rev/min		
		Baseload Power	Prime power	Standby Power	Baseload Power	Prime power	Standby Power
Gross engine power	kWm	497	581	646	529	640	694
Fan power	kWm	26			44		
Net engine power	kWm	471	555	620	485	596	650
BMEP gross	kPa	1729	2021	2247	1533	1855	2012
Combustion air flow	m ³ /min	49	60	64	58	61	67
Exhaust gas temperature max. after turbo	°C	410					
Exhaust gas flow (max)	m ³ /min	171			180		
Boost pressure ratio	-	2.7	3.1	3.4	2.8	3.3	3.5
Mechanical efficiency	%	90	90	90	90	90	90
Overall thermal efficiency	%	44	43	42	41	41	40
Friction power and pumping losses	kWm	70			75		
Mean piston speed	m/s	9,5			11,4		
Engine coolant flow	l/s	10			12		
Cooling fan airflow	m ³ /min	1200			1320		
Typical Genset electrical output 0.8pf 25 °C (100 kPa)	kVA	550	650	725	563	688	756
	kWe	440	520	580	450	550	605
Assumed alternator efficiency	%	94			93		

General installation 4006-23TAG2A

Designation	Units	50 Hz 1500 rev/min			60 Hz 1800 rev/min		
		Baseload power	Prime power	Standby power	Baseload Power	Prime power	Standby power
Gross engine power	kWm	521	646	711	554	684	759
Fan power	kWm	26			44		
Net engine power	kWm	495	620	685	510	640	715
BMEP gross	kPa	1812	2247	2473	1606	1983	2200
Combustion air flow	m³/min	60	64	71	62	65	73
Exhaust gas temperature max. after turbo	°C	430					
Exhaust gas flow (max)	m³/min	180			190		
Boost pressure ratio	-	3.0	3.4	3.6	3.2	3.4	3.6
Mechanical efficiency	%	90	90	90	90	90	90
Overall thermal efficiency	%	43	42	41	41.5	41	40
Friction power and pumping losses	kWm	70			75		
Mean piston speed	m/s	9,5			11,4		
Engine coolant flow	l/s	10			12		
Cooling fan airflow	m³/min	1200			1320		
Typical Genset electrical output 0.8pf 25 °C (100 kPa)	kVA	585	730	800	600	750	844
	kWe	468	584	640	480	600	675
Assumed alternator efficiency	%	95			94		

General installation 4006-23TAG3A

Designation	Units	50 Hz 1500 rev/min			60 Hz 1800 rev/min		
		Baseload power	Prime power	Standby power	Baseload power	Prime power	Standby power
Gross engine power	kWm	566	705	786	614	759	839
Fan power	kWm	26			44		
Net engine power	kWm	540	679	760	570	715	795
BMEP gross	kPa	1969	2452	2734	1780	2200	2432
Combustion air flow	m³/min	60	69	73	68	76	78
Exhaust gas temperature max. after turbo	°C	500					
Exhaust gas flow (max)	m³/min	193			209		
Boost pressure ratio	-	3.1	3.5	3.8	3.35	3.6	3.79
Mechanical efficiency	%	90	90	90	90	90	90
Overall thermal efficiency	%	43	41	40	41.5	40.5	39.5
Friction power and pumping losses	kWm	70			75		
Mean piston speed	m/s	9,5			11,4		
Engine coolant flow	l/s	10			12		
Cooling fan airflow	m³/min	1200			1320		
Typical Genset electrical output 0.8pf 25 °C (100 kPa)	kVA	640	800	900	675	844	938
	kWe	512	640	720	540	675	750
Assumed alternator efficiency	%	95			95		

Rating Definitions

Baseload Power

Unlimited hours usage with an average load factor of 100% of the published Baseload Power. No overload is permitted on Baseload Power.

Prime Power

Unlimited hours usage with an average load factor of 80% of the published Prime Power over each 24 hour period. A 10% overload is available for 1 hour in every 12 hours operation.

Standby Power

Limited to 500 hours annual usage with an average load factor of 80% of the published Standby Power rating over each 24 hour period. Up to 300 hours of annual usage may be run continuously. No overload is permitted on Standby Power.

Energy balance

4006-23TAG1A

Designation	Units	50 Hz 1500 rev/min ½ TA Luft			50 Hz 1500 rev/min Best SFC			1800 rev/min		
		Baseload power	Prime power	Standby power	Baseload power	Prime power	Standby power	Baseload power	Prime power	Standby power
Energy in fuel	kW	1239	1463	1630	1175	1359	1519	1329	1621	1822
Energy in power output (gross)	kW	497	581	646	497	581	646	529	640	694
Energy to cooling fan	kW	26			26			44		
Energy in power output (net)	kW	470	555	620	471	555	620	485	596	650
Energy to exhaust	kW	401	490	540	373	406	431	440	550	630
Energy to coolant and oil	kW	180	200	221	150	180	221	190	220	260
Energy to radiation	kW	36	42	48	35	42	46	38	46	51
Energy to charge coolers	kW	125	150	175	120	150	175	132	165	187

4006-23TAG2A

Designation	Units	50 Hz 1500 rev/min ½ TA Luft			50 Hz 1500 rev/min Best SFC			1800 rev/min		
		Baseload power	Prime power	Standby power	Baseload power	Prime power	Standby power	Baseload power	Prime power	Standby power
Energy in fuel	kW	1300	1600	1790	1231	1519	1680	1388	1737	1937
Energy in power output (gross)	kW	521	646	711	521	646	711	554	684	759
Energy to cooling fan	kW	26			26			44		
Energy in power output (net)	kW	495	620	685	495	620	685	509	639	714
Energy to exhaust	kW	420	571	607	387	465	499	500	620	680
Energy to coolant and oil	kW	190	221	230	160	191	230	157	200	243
Energy to radiation	kW	39	48	52	38	45	50	41	50	55
Energy to charge coolers	kW	130	175	190	125	172	190	136	183	200

4006-23TAG3A

Designation	Units	50 Hz 1500 rev/min ½ TA Luft			50 Hz 1500 rev/min Best SFC			1800 rev/min		
		Baseload power	Prime power	Standby power	Baseload power	Prime power	Standby power	Baseload power	Prime power	Standby power
Energy in fuel	kW	1400	1834	2051	1324	1666	1876	1522	1900	2150
Energy in power output (gross)	kW	566	705	786	566	705	786	614	759	839
Energy to cooling fan	kW	26			26			44		
Energy in power output (net)	kW	540	679	760	540	679	760	569	714	794
Energy to exhaust	kW	447	620	690	398	457	515	490	595	698
Energy to coolant and oil	kW	200	270	300	180	270	300	216	290	320
Energy to radiation	kW	42	54	60	40	54	60	45	58	64
Energy to charge coolers	kW	145	185	215	140	180	215	157	198	229

Note: ½ TA Luft figures have been developed to comply with ½TA Luft as 1986 with 2000 mg/m³ NOx @ 5% O₂ limits for power generation engines.

Cooling system

Recommended coolant: 50% inhibited ethylene glycol or 50% inhibited propylene glycol and 50% clean fresh water. Where there is no likelihood of ambient temperature below 10 °C then clean 'soft' water may be used, treated with 1% by volume of Perkins inhibitor in the cooling system. The inhibitor is available from Perkins.

Nominal jacket water pressure in crankcase. 170 kPa
 Maximum top temperature (standby). 98 °C
 Maximum static pressure head on pump... 7 m
 Draw down capacity 22 litres
 Maximum permissible restriction to coolant pump flow... .. 20 kPa
 Thermostat operating range... .. 71 - 85 °C
 Ambient cooling clearance (open Electropak prime power) based on air temp at fan 3 °C above ambient.

Maximum additional restriction (duct allowance) to cooling airflow. (TAG1A, 2A & 3A standby power) and resultant minimum airflow					
Ambient clearance: 50% Glycol		Duct allowance mm H ₂ O		Min airflow m ³ /sec	
rev/min		rev/min		rev/min	
1500	1800	1500	1800	1500	1800
43 °C	43 °C	13	20	20	22

Maximum additional restriction (duct allowance) to cooling airflow. (TAG1A, 2A & 3A standby power) and resultant minimum airflow					
Ambient clearance: inhibited coolant		Duct allowance mm H ₂ O		Min airflow m ³ /sec	
rev/min		rev/min		rev/min	
1500	1800	1500	1800	1500	1800
50 °C	50 °C	13	20	20	22

The above information at 1500 rev/min applies for ½ TA luft and Best SFC ratings.

Radiator

Radiator face area 2,569 m²
 Rows and materials 3 rows of brass tubes
 Gills per inch and material (jacket water)... Copper fin at 14 gills/in
 Gills per inch and material (charge air section)... .. Copper fin at 10 gills/in
 Width and height of matrix
 -height 1600 mm
 -width 1606 mm
 Weight (dry) radiator 570 kg
 Total coolant capacity 105 litres
 Pressure cap setting 70 kPa

Coolant jacket data	Units	1500 rev/min	1800 rev/min
Coolant flow	l/s	10	12
Coolant exit temperature (max)	°C	98	98
Coolant entry temperature (min)	°C	70	70

Charge cooler, integral with radiator

Face area..... 1,622 m²

Coolant pump

Speed and method of drive 1.4 x e rev/min Gear

Fan

Type Engine mounted
 Speed 1500/1800..... 1170/1404 rev/min
 Diameter 1,2 m
 Number of blades..... 8
 Material Steel
 Drive ratio..... 0.78 : 1

Lubrication system

Recommended lubricating oil to conform with the specification of API CG4 15W/40

Lubricating oil capacity:

Sump maximum 113,4 litres
 Sump minimum 90,7 litres

Lubricating oil temperature

Normal 80 °C
 Maximum 105 °C

Lubricating oil pressure at rated speed:

Minimum 240 kPa
 Oil relief valves opens 300 kPa
 Oil filter spacing... .. 40 microns
 Sump drain plug tapping size G1
 Oil pump speed and method of drive 1.4 x e rev/min, gear
 Oil pump flow 1500/1800 rev/min 3,7/4,4 litres/sec
 Oil consumption as a percentage of full load fuel consumption less than 0.25%

Normal operating angles

Front and rear 5° maximum
 Side tilt 10° maximum

Electrical system

Type Insulated return
 Alternator 40 amps @ 28 volts, stabilised output at 20 °C ambient
 Starter motor power 7,5 kW
 Number of teeth on flywheel 190
 Number of teeth on starter motor 12
 Minimum cranking speed 120 rev/min
 Pull in current of starter motor solenoid... .. 30 amps at 24 volts
 Hold in current of starter motor solenoid 9 amps at 24 volts
 Engine stop solenoid... .. 24 volts
 Pull in current of stop solenoid 60 amps at 24 volts
 Pull in current of stop solenoid 1.1 amps at 24 volts

Starting requirements

Temperature range	
To 10 °C (50 °F)	Oil: CG4 15W40
	Starter: 1 x 24 volts
	Battery: 2 x 12V x Ah 143
	max. breakaway
	current: 1000 amps
	Cranking current: 600 amps
	Aids: Not necessary

Notes:

- The battery capacity is defined by the 20 hour rate at 0 °C
- The oil specification should be for the minimum ambient temperature as the oil will not be warmed by the immersion heater
- The breakaway current is dependant on the battery capacity available. Cables should be capable of handling the transient current which may be up to double the steady cranking current.

Fuel system

Recommended fuel ... To conform to BS2869 1998 Class A1, A2
 Type of injection system ... Direct injection
 Fuel injector ... Combined unit injector
 Fuel injector pressure ...
 ... 220 ATS (NOP) 1400 bar maximum operating pressure
 Delivery at 1500/1800 rev/min ... 660/810 litres/hour
 Fuel delivery pump pressure ... 300 kPa
 Fuel lift pump maximum suction head ... 2.5 m
 Fuel return maximum pressure head ...
 ... 3m Above fuel delivery pump
 Fuel filter spacing ... 10 microns
 Governor type ... Electronic

Fuel consumption gross. (½ TA Luft)

	g/kW/h		l/h	
	1500	1800	1500	1800
4006-23 TAG1A				
Standby	203	210	152.1	170.1
Prime	202	205	136.2	152.5
Baseload	193	201	115.6	124.1
75% Prime	199	200	101.6	114.3
50% Prime	198	200	67.6	79.7
4006-23 TAG2A				
Standby	203	215	168.1	189.6
Prime	203	211	152.8	168.2
Baseload	195	200	121.4	129.3
75% Prime	200	202	113.5	123.3
50% Prime	198	202	75.3	85.6
4006-23 TAG3A				
Standby	212	219	193.5	213.5
Prime	204	215	167.4	189.6
Baseload	197	203	133.1	145.2
75% Prime	203	204	126.1	137.7
50% Prime	203	195	84.0	91.3

Fuel consumption gross. (Best SFC)

	g/kW/h		l/h	
	1500	1800	1500	1800
4006-23 TAG1A				
Standby	199	210	149.5	170.1
Prime	198	205	133.8	152.5
Baseload	200	201	115.6	124.1
75% Prime	202	200	103.8	114.3
50% Prime	205	200	72.2	79.7
4006-23 TAG2A				
Standby	200	215	165.3	189.6
Prime	199	211	149.5	168.2
Baseload	200	200	121.2	129.3
75% Prime	201	202	114.8	123.3
50% Prime	203	202	79.3	85.6
4006-23 TAG3A				
Standby	202	219	184.6	213.5
Prime	200	215	164.0	189.6
Baseload	198	203	130.3	145.2
75% Prime	200	204	124.4	137.7
50% Prime	203	195	86.2	91.3

Induction system

Maximum air intake restriction of engine:
 Clean filter ... 127 mm H₂O
 Dirty filter ... 380 mm H₂O
 Air filter type ... dry - paper

Exhaust system

Exhaust outlet size (internal) ... 2 x 152,4 mm
 Exhaust back pressure for total system - TAG1A ... 710 mm H₂O
 Exhaust back pressure for total system - TAG2A ... 610 mm H₂O
 Exhaust back pressure for total system - TAG3A ... 610 mm H₂O
 For recommended pipe sizes see the installation manual.

Engine Mounting

Maximum additional load applied to flywheel due to all rotating components ... 650 kg
 Position of engine centre of gravity (wet)
 -forward of the rear face of the crankcase ... 625 mm
 -above the crankshaft centre line ... 140 mm

Typical Load Acceptance (Cold)

At 1500 rev/min

	Initial Load Application When engine reaches rated speed (15 seconds max. after engine starts to crank)				2nd Load Application Immediately after engine has recovered to rated speed (5 seconds after initial load application)			
Engine type	Prime Power %	Load kWm.kWe Nett	Transient Frequency Deviation %	Frequency recovery time seconds	Prime Power %	Load kWm.kWe Nett	Transient Frequency Deviation %	Frequency recovery time seconds
4006-23TAG1A	73	401/377	≤ -10	5	27	154/143	≤ -10	5
4006-23TAG2A	69	426/400	≤ -10	5	31	194/184	≤ -10	5
4006-23TAG3A	66	448/421	≤ -10	5	34	231/219	≤ -10	5

At 1800 rev/min

	Initial Load Application When engine reaches rated speed (15 seconds max. after engine starts to crank)				2nd Load Application Immediately after engine has recovered to rated speed (5 seconds after initial load application)			
Engine type	Prime Power %	Load kWm.kWe Nett	Transient Frequency Deviation %	Frequency recovery time seconds	Prime Power %	Load kWm.kWe Nett	Transient Frequency Deviation %	Frequency recovery time seconds
4006-23TAG1A	75	438/412	≤ -10	5	25	158/138	≤ -10	5
4006-23TAG2A	70	447/420	≤ -10	5	30	193/180	≤ -10	5
4006-23TAG3A	67	483/454	≤ -10	5	33	232/221	≤ -10	5

The above complies with requirements of Classification 3 & 4 of ISO 8528 - 12 and G2 operating limits stated in ISO 8528 - 5.

The above figures were obtained under test conditions as follows:

Engine block temperature... ..45 °C

Alternator efficiency94%

Minimum ambient temperature10 °C

Isochronous governing

Under frequency roll off (UFRO) set to1 Hz below rated frequency

Typical alternator inertia.20 kgm²

All tests were conducted using an engine installed and serviced to Perkins Engines Company Limited recommendations.

The information given on Technical Data sheets is for standard engines only. For ratings other than shown contact the Applications Department.

The information given in this document is for guidance only.

General Arrangement Drawings

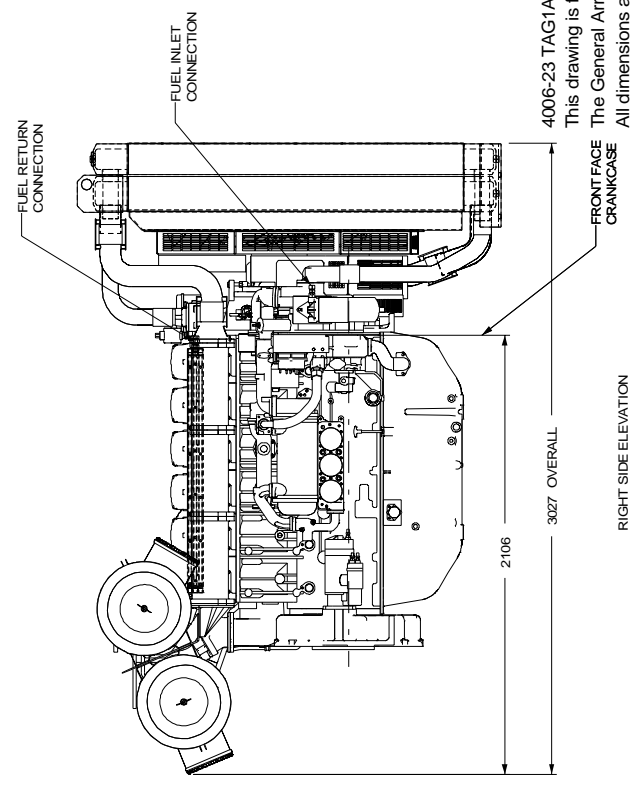
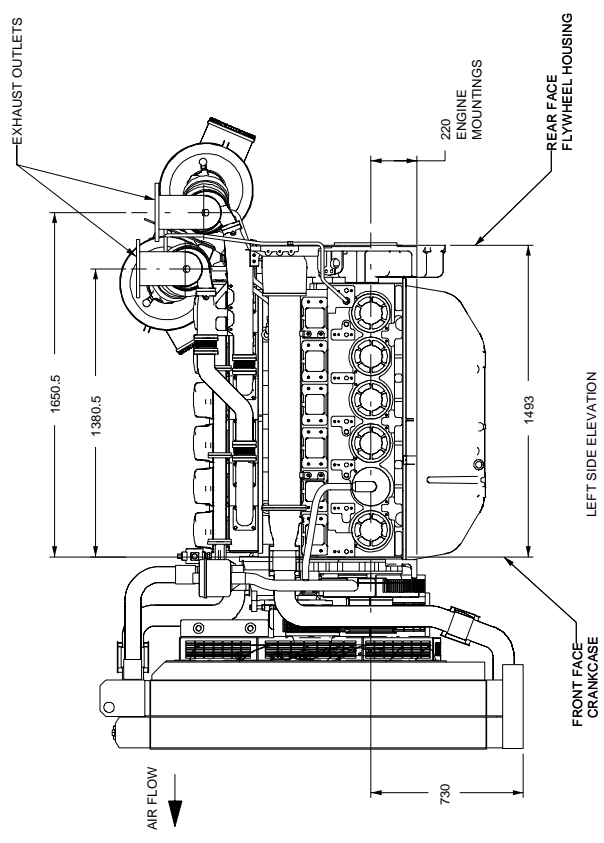
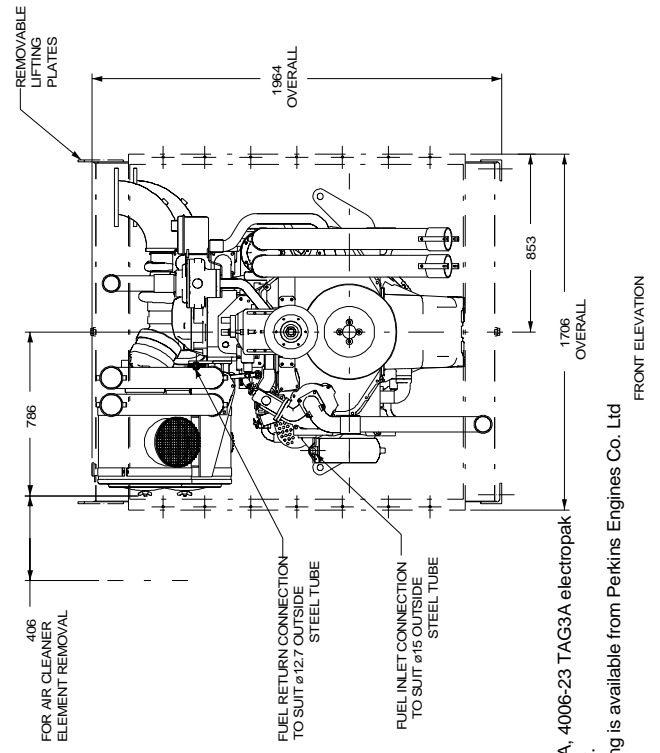
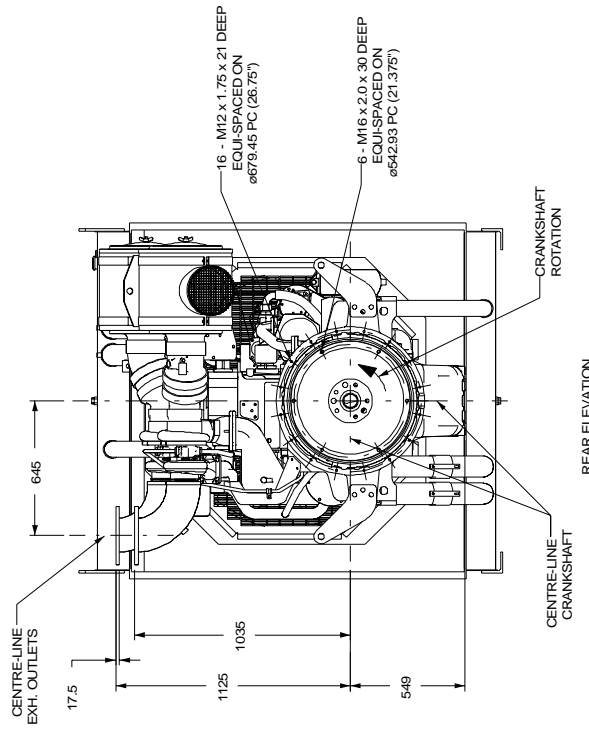

4006-23 TAG1A, 4006-23 TAG2A, 4006-23 TAG3A electropak
 This drawing is for guidance only.
 The General Arrangement drawing is available from Perkins Engines Co. Ltd
 All dimensions are in millimeters.

Exhaust, flywheel and mounting details:

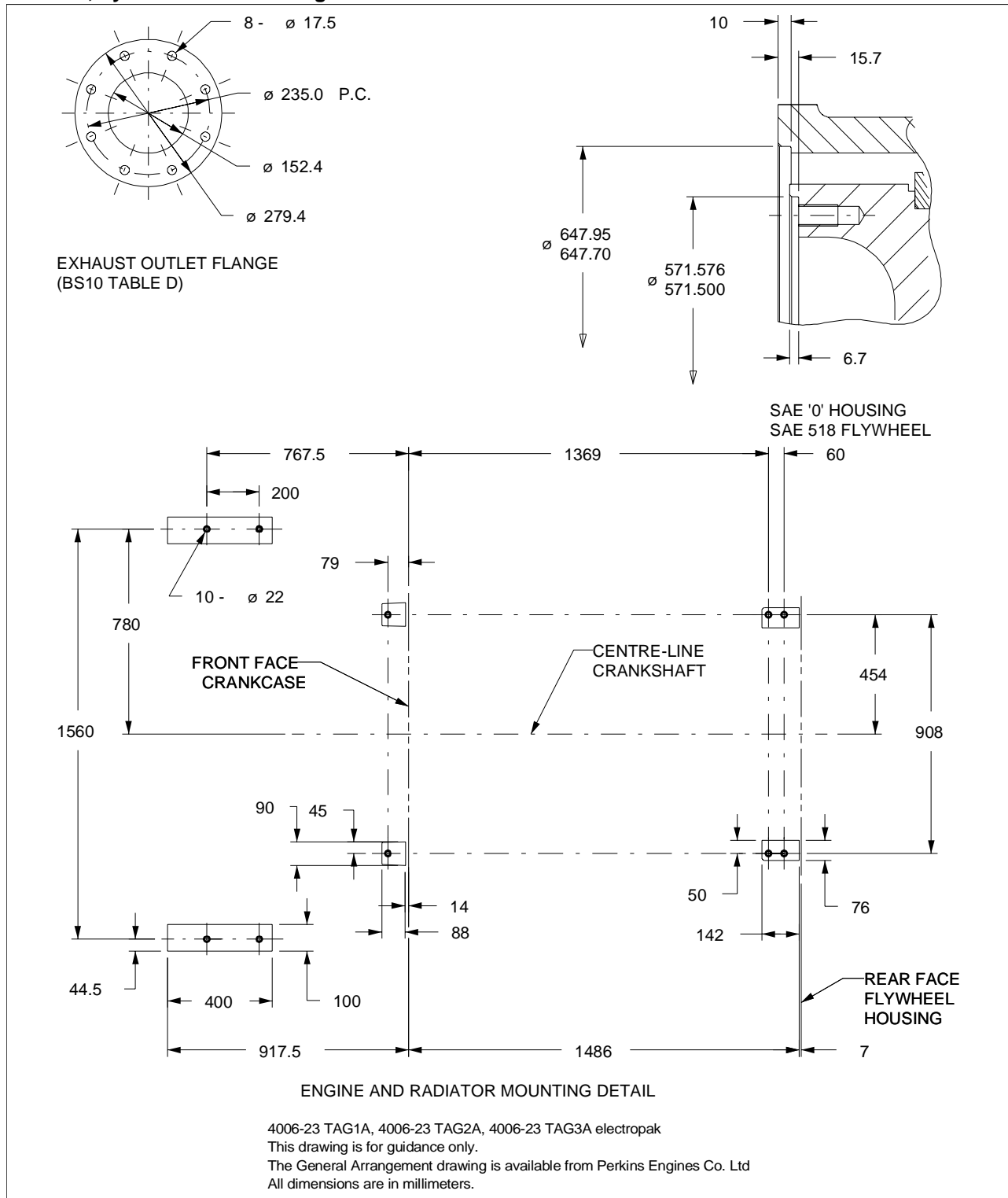

Perkins Engine Company Limited

Peterborough PE1 5NA United Kingdom
Telephone +44 (0) 1733 583000
Fax +44 (0) 1733 582240
www.perkins.com

All information in the document is substantially correct at the time of printing but may be subsequently altered by the company.

Distributed by