

4000 Series

4012-46TAG3A

Diesel Engine – Electropak

1583 kWm 1500 rpm
1583 kWm 1800 rpm

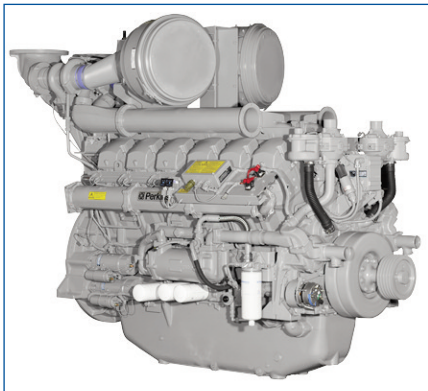

Economic power

- Individual four valve per cylinder heads give optimised gas flows, whilst digitally governed unit fuel injectors ensure ultra-fine fuel atomisation and hence controlled rapid combustion, for efficiency and economy
- Commonality of components with other engines in the 4000 Series family allows reduced parts stocking levels

Reliable power

- Developed and tested using latest engineering techniques
- Piston temperature are controlled by an advanced gallery jet cooling system
- All engines are tolerant of a wide range of temperatures without derate
- Perkins global product support is designed to enhance the customer experience of owning a Perkins powered machine. We deliver this through the quality of our distribution network, extensive global coverage and a range of Perkins supported OEM partnership options. So whether you are an end-user or an equipment manufacturer our engine expertise is essential to your success

Clean, efficient power

- Exceptional power to weight ratio and compact size for easier transportation and installation
- New designed radiator assemblies with corrosion inhibiting powder coated finish; fewer pipe joints and easier access to reduce maintenance times
- Designed to provide excellent service access for ease of maintenance
- Engines designed to comply with major international standards
- Low gaseous emissions that will satisfy the requirements of 1/2 TA Luft (1986)

Product support

- Perkins actively pursues product support excellence by ensuring our distribution network invest in their territory - strengthening relationships and providing more value to you, our customer
- Through an experienced global network of distributors and dealers, fully trained engine experts deliver total service support around the clock, 365 days a year. They have a comprehensive suite of web based tools at their fingertips covering technical information, parts identification and ordering systems, all dedicated to maximising the productivity of your engine
- Throughout the entire life of a Perkins engine, we provide access to genuine OE specification parts and service. We give 100% reassurance that you receive the very best in terms of quality for lowest possible cost .. wherever your Perkins powered machine is operating in the world

The Perkins 4000 Series family of 6, 8, 12 and 16 cylinder diesel engines was designed in advance of today's uncompromising demands within the power generation industry and includes superior performance and reliability. The 4012-46TAG3A Electropak is a newly developed turbocharged, air-to-air charge cooled, 12 cylinder diesel engine. Offered with either Temperate or Tropical cooling packages (with or without fuel oil cooling). Their premium design and specification features provide economic and durable operation as well as exceptional power to weight ratio, improved serviceability, low gaseous emissions, overall performance and reliability essential to the power generation market.

Engine Speed (rev/min)	Type of Operation	Typical Generator Output (Net)		Engine Power			
				Gross		Net	
		kVA	kWe	kWm	bhp	kWm	bhp
1500	Baseload Power	1425	1140	1260	1690	1200	1609
	Prime Power	1710	1368	1500	2012	1440	1931
	Standby (maximum)	1880	1504	1643	2203	1583	2123
1800	Baseload Power	1425	1140	1260	1690	1200	1609
	Prime Power	1710	1368	1500	2012	1440	1931
	Standby (maximum)	1880	1504	1643	2203	1583	2123

The above ratings represent the engine performance capabilities guaranteed within plus or minus 3% at the reference conditions equivalent to those specified in ISO 8528/1, ISO 3046/1, BS 5514/1.

Rating conditions: 25°C air inlet temperature, barometric pressure 100 kPa, relative humidity 30%. Please consult your distributor or the factory for ratings in other ambient conditions.

Note: For full ratings please refer to Perkins Engines Company Limited. All electrical ratings are based on an average alternator efficiency and a power factor of 0.8.

Fuel specification: BS2869: Class A2.

Rating Definitions: **Baseload Power:** Power available for continuous full load operation. No overload is permitted. **Prime Power:** Power available for variable load with an average load factor not exceeding 80% of the prime power rating in any 24 hour period. Overload of 10% permitted for 1 hour in every 12 hours operation. **Standby (maximum):** Power available at variable load in the event of a main power network failure up to a maximum of 500 hours per year. No overload is permitted.

4000 Series

4012-46TAG3A

Standard ElectropaK Specification

Air inlet

- Mounted air filters and turbochargers

Fuel System

- Direct fuel injection system with fuel lift pump
- Governing to ISO 8528-5 class G2 with isochronous capability
- Full-flow spin-on fuel oil filters

Lubrication System

- Wet sump with filler and dipstick
- Full-flow spin-on oil filters
- Engine jacket water/lub oil temperature stabiliser

Cooling System

- Two twin thermostats
- System designed for ambients up to 50°C
- Powder coated radiator comprising: water radiator; air charge cooled radiator; fuel oil cooling (optional); all pipes, hoses and clips; fan; pulleys; fan belts and safety guards

Electrical Equipment

- 24 volt starter motor and 24 volt alternator with integral regulator and DC output
- Overspeed switch and magnetic pickup
- Turbine inlet temperature shutdown switch
- Twin high coolant temperate shutdown switches
- Twin low oil pressure shutdown switches

Flywheel and Housing

- Flywheel to SAE J620 size 18
- SAE 00 flywheel housing

Optional Equipment

Choice of temperate or tropical radiators available dependant on operational cooling requirements

Fuel oil cooler integral to the radiator assembly

Immersion heater with thermostat

Note: This list is not exhaustive, for further options please contact your Perkins representative

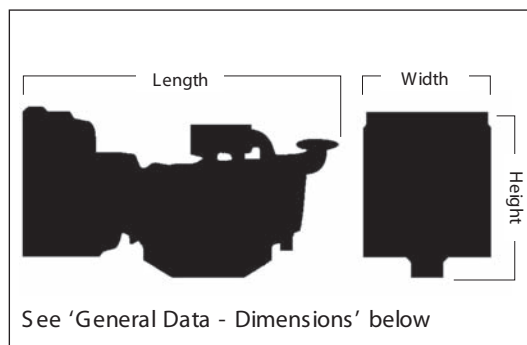

Engine Speed	Fuel Consumption			
	1500 rev/min		1800 rev/min	
	g/kWh	l/hr	g/kWh	l/hr
Standby	211	405	213	300
Prime power	208	370	213	361
Continuous baseload	207	310	210	391
75% of prime power	206	275	177	226
50% of prime power	202	187	221	188

General Data

Number of cylinders	12	
Cylinder arrangement	60° Vee form	
Bore and stroke	160 x 190 mm	
Displacement	45.842 litres	
Induction system	Turbocharged and air to air charge cooled	
Cycle	4 stroke	
Combustion system	Direct injection	
Compression ratio	13.6:1	
Rotation	Anti-clockwise, viewed from flywheel end	
Cooling system	Water-cooled	
Firing order	1A, 6B, 5A, 2B, 3A, 4B, 6A, 1B, 2A, 5B, 4A, 3B	
Total lubrication system capacity	177 litres	
Total weight (dry)	4400 kg	
Total coolant capacity (1500 rpm)	207 litres	Temperate Tropical 210 litres
Total coolant capacity (1800 rpm)	225 litres	209 litres
Dimensions	Length	3915 mm 3883 mm
	Width	2198 mm 2164 mm
	Height	2259 mm 2610 mm

Final weight and dimensions will depend on completed specification

Industrial Power Generation Ltd,
Carcroft Enterprise Park,
Station Road, Carcroft,
Doncaster, DN6 8DD, UK
sales@generator.co.uk
Tel: 00 44 (0)845 166 5537
Fax: 00 44 (0)1302 721202



Industrial Power Generation Ltd