



4000 Series

4016TAG1A

Diesel Engine – Electro Unit

1690 kWm 1500 rev/min

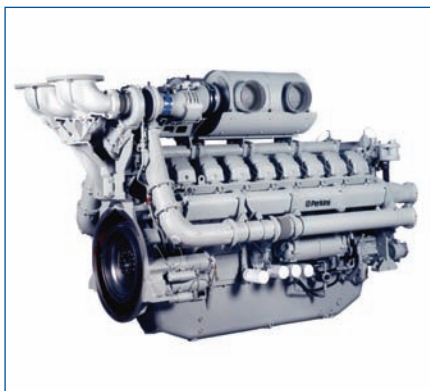

Economic power

- Individual 4 valve cylinder heads give optimised gas flows, while unit fuel injectors ensure ultra fine fuel atomisation and hence controlled rapid combustion for efficiency and economy.
- Commonality of components with other engines in 4000 Series family allows reduced parts stocking levels.

Reliable power

- Developed and tested using latest engineering techniques.
- Piston temperatures are controlled by an advanced gallery jet cooling system.
- All engines are tolerant of a wide range of temperatures without derate.
- Perkins global product support is designed to enhance the customer experience of owning a Perkins powered machine. We deliver this through the quality of our distribution network, extensive global coverage and a range of Perkins supported OEM partnership options. So whether you are an end-user or an equipment manufacturer our engine expertise is essential to your success.

Clean, efficient power

- Exceptional power to weight ratio and compact size for easier transportation and installation.
- Designed to provide excellent service access for ease of maintenance.
- Engines designed to comply with major international standards.
- Low gaseous emissions for cleaner operation.

Product Support

- Perkins actively pursues product support excellence by ensuring our distribution network invest in their territory - strengthening relationships and providing more value to you, our customer
- Through an experienced global network of distributors and dealers, fully trained engine experts deliver total service support around the clock, 365 days a year. They have a comprehensive suite of web based tools at their fingertips covering technical information, parts identification and ordering systems, all dedicated to maximising the productivity of your engine
- Throughout the entire life of a Perkins engine, we provide access to genuine OE specification parts and service. We give 100% reassurance that you receive the very best in terms of quality for lowest possible cost .. wherever your Perkins powered machine is operating in the world

The Perkins 4000 Series family of 8, 12 and 16 cylinder diesel engines was designed in advance of today's uncompromising demands within the power generation industry and includes superior performance and reliability.

The 4016TAG1A is a turbocharged, air to air charge cooled, 16 cylinder vee form diesel engine. Its premium design and specification features provide economic and durable operation as well as exceptional power to weight ratio, improved serviceability, low gaseous emissions, overall performance and reliability essential to the power generation market. The 4016TAG1A is specially tuned for improved load acceptance response in standby duty.

Engine Speed (rev/min)	Type of Operation	Typical Generator Output (Net)		Engine Power			
		kVA	kWe	Gross		Net	
				kWm	bhp	kWm	bhp
1500	Baseload Power	1463	1170	1270	1703	1219	1635
	Prime Power	1844	1476	1588	2130	1537	2061
	Standby (maximum)	2028	1622	1741	2334	1690	2266

The above ratings represent the engine performance capabilities within plus or minus 3% at the reference conditions equivalent to those specified in ISO 8528/1, ISO 3046/1, BS 5514/1.

Ratings conditions: 25°C air inlet temperature, barometer pressure 100 kPa, relative humidity 30%. Please consult your distributor or the factory for ratings in ambient conditions.

Note: For full ratings please refer to Perkins Engines Company Limited. All electrical ratings are based on an average alternator efficiency and a power factor of 0.8.

Fuel specification: BS 2869 Class A1 + A2 or ASTM D975 No 2D.

Rating Definitions

Continuous Baseload: Power available for continuous full load operation. No overload is permitted.

Prime Power: Power available for variable load with an average load factor not exceeding 80% of the prime power rating in any 24 hour period. Overload of 10% permitted for 1 hour in every 12 hours operation.

Standby (maximum): Power available at variable load in the event of a main power network failure for a maximum of 500 hours per year. No overload is permitted.

4000 Series

4016TAG 1A

Standard Electro Unit Specification

Air inlet

- Mounted air filters and turbochargers

Fuel system

- Unit fuel injectors with lift pump and hand stop control
- Electronic governor to ISO 3046 Part 4 class A1
- Full-flow spin-on fuel oil filters

Lubrication system

- Wet sump with filler and dipstick
- Full-flow spin-on oil filters
- Engine jacket water/lub oil temperature stabiliser

Cooling system

- Twin gear driven circulating pumps
- Two twin thermostats
- Crankshaft pulley for fan drive

Electrical equipment

- 24 volt starter motor and 24 volt/40 amp alternator with integral regulator and DC output
- 24 volt combined high coolant temperature/low oil pressure switch
- Overspeed switch and magnetic pickup
- Turbine inlet temperature shutdown switch
- 24 volt stop solenoid (energised to run)

Flywheel and housing

- Flywheel to SAE J620 size 18
- SAE 00 flywheel housing

Optional Equipment

The following optional equipment is available to make up the specifications to Perkins ElectropaK specification:

Tropical radiator including: Water pipes, clips and hoses

Fan, fan guards and belts

Other optional extra equipment available

Twin heavy duty air cleaner – paper element with pre-cleaner

Changeover lubricating oil filter

Changeover fuel oil filter

Immersion heater with thermostat

Water pipes, clips and hoses for radiator

Air starters

Instrument panel

NB This list is not exhaustive, further options may be available to meet to particular applications on enquiry to Perkins Sales Department

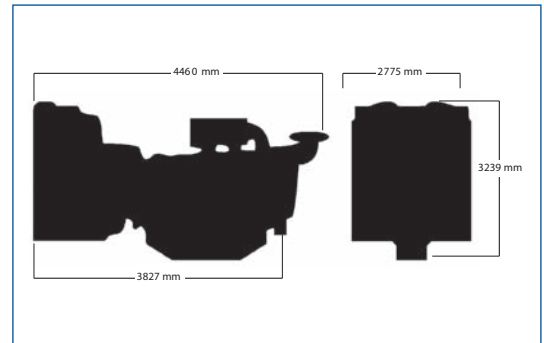

Fuel Consumption (g/kWh)	
Engine Speed	1500 rev/min 4016TAG 1A
Standby Maximum Rating	207
Prime Power Rating	205
Continuous Baseload Rating	199
75% of Prime Power Rating	198
50% of Prime Power Rating	198
25% of Prime Power Rating	218

General Data

Number of cylinders	16
Cylinder arrangement	60° Vee form
Cycle	4 stroke
Induction system	Turbocharged Air to air charge cooled
Combustion system	Direct injection
Cooling system	Water-cooled
Displacement	61.123 litres
Bore and stroke	160 x 190 mm
Compression ratio	13.6:1
Direction of rotation	Anti-clockwise, viewed from flywheel end
Firing order	1A, 1B, 3A, 3B, 7A, 7B, 5A, 5B, 8A, 8B, 6A, 6B, 2A, 2B, 4A, 4B
Total lubrication system capacity	237.2 litres
Total coolant capacity	Electro Unit 95 litres ElectropaK 316 litres
Length	3302 mm
Width	1723 mm
Height	2128 mm
Total weight (dry)	5570 kg

Final weight and dimensions will depend on completed specification

Industrial Power Generation Ltd,
Carcroft Enterprise Park,
Station Road, Carcroft,
Doncaster, DN6 8DD, UK
sales@generator.co.uk
Tel: 00 44 (0)845 166 5537
Fax: 00 44 (0)1302 721202



Industrial Power Generation Ltd